

► Our technology. Your success.

Pumps • Valves • Service



Amarex IN – Submersible Motor Pump for Handling Waste Water



Applications:

- Waste water transport
- Waste water treatment
- Sludge treatment
- Storm water transport

More information:

www.ksb.com/products

Amarex IN – Submersible Motor Pump for Handling Waste Water

- 1 Significant energy savings**
High efficiency through optimized hydraulic system
- 2 No risk of leakage**
With 2 mechanical seals
- 3 Flexibility**
Optional choice of impeller material with stainless steel and cast iron variant. Various installation types to suit different building structures
- 4 Minimum storage costs**
Maximum interchangeability between motor housing, motor housing cover & bearing bracket
- 5 Easy rewinding**
Access from both sides of the motor for easy pull out/ in of stator, easy rewinding & commissioning
- 6 Monitoring**
Sensors trigger a warning in the event of overheating or ingress of moisture

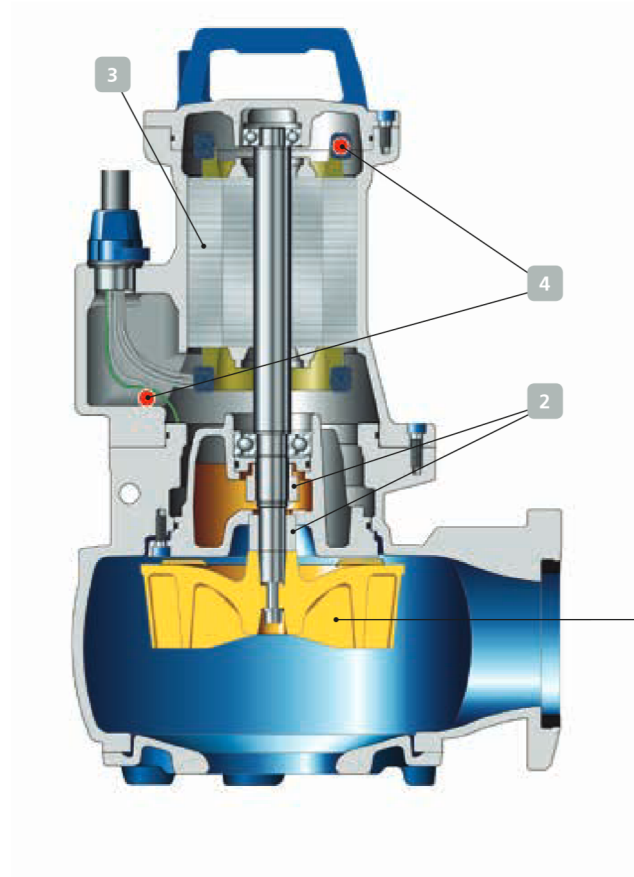

Impellers



Type S



Type F



Guide wire arrangement



Transportable installation

Technical data

Pump sizes	DN 65 and DN 100
Flow rate	up to 46 l/s
Head	up to 49 m
Temperature Standard (ULG) (up to 80 °C for a short period of time)	up to 55 °C
Speed	1,450 rpm and 2,900 rpm
Power	up to 4.2 kW